

Instruction Manual



Electrical Actuator Unit Type EA 11

The technical data is not binding and not an expressly warranted characteristic of the goods. It is subject to change. Please consult our General Conditions of Supply.

Table of Contents

	Page
1. Introduction/General Information	4
2. Manufacturer's Declaration	4
3. Intended Use	5
4. Safety Tips	6
4.1 Due Care Required of the Operator	
4.2 Special Hazards	
4.3 Transport and Storage	
5. Actuator Design	8
5.1 Wiring Diagram for Standard Version	
6. Valve Design	10
6.1 Mounting on the Ball Valve 107	
6.2 Overview of Ball Valve System Type 107	
7. Setting Up the Actuator/Valve	14
7.1 Emergency Manual Override	
8. Technical Specifications for EA 11	16
9. Mounting and Connecting the Supplementary Kits	17
9.1 Heating Element	
9.2 Fail-safe Return	
9.3 Additional Limit Switches	
10. Fastening Plate	23
11. Troubleshooting	24
12. Subcomponents/Spare Parts	25

1. Introduction

This instruction manual contains all the pertinent information on the design, installation and operation of the electrical actuator type EA 11.

General Information

Hazard notices

Hazard notices are used in this manual to warn you of possible injuries or damages to property. Please read and abide by these warnings at all times!

Warning symbols



Danger



Warning



Caution

Meaning

Imminent acute danger!

Failure to comply could result in death or extremely serious injury.

Possible acute danger!

Failure to comply could result in serious injury.

Dangerous situation!

Failure to comply could lead to injury or damage to property.

2. EC Manufacturer's Declaration

The manufacturer, **Georg Fischer Piping Systems Ltd, CH-8201 Schaffhausen**, declares that the **electrical actuator EA 11** is not a ready-to-use machine in the sense of the EC Machine Directive and cannot therefore meet all the requirements of this directive.

Operation of these actuators is prohibited until conformity of the entire system into which the valve and the actuator have been installed is established according to the EC Directives listed below.

Applicable EC Directives:

72/23	EEC	EC Low Voltage Directive
89/336	EEC	EC Directive on Electromagnetic Compatibility

Modifications to the actuator which have an effect on the technical data given in this instruction manual and its intended use, i.e. significantly alter the actuator, render this manufacturer's declaration null and void.



Warning

3. Intended Use

When mounted on a valve and connected to a system control, the purpose of this actuator is to

- actuate valves with 90° pivoting (ball valves and butterfly valves),
- indicate the previously calibrated end positions of the valve via electrical signal to the system control (accessory), and
- provided that the actuator data corresponds to the electrical control and the valve and
- in case of interruption in the supply voltage, warrant that the actuator/valve remains in the current position. Please use emergency manual override or install fail-safe return.



Warning

The actuator is not intended for uses other than those listed here. If the instructions contained in this manual are not observed, the manufacturer is excluded from all liability for the above mentioned products.

4. 4. Safety Tips

4.1 Due care required of the operator

The actuator described herein was designed and manufactured with consideration to the respective harmonized European standards. It corresponds to the latest technology and the technical specifications contained under Section 8.



Warning

Safety on the job can, however, only be realized if the operator warrants that

- the actuator is only used as indicated under Section 3,
- he is familiar with this instruction manual and the manual of the corresponding valve and adheres to the instructions contained therein and
- he has taken the necessary measures against electrostatic influence.

4.2 Special hazards



Warning

Under normal conditions, the actuator may only be operated with the cover closed.

If work is performed on the actuator with the cover removed, the supply and control voltage must first be disconnected. Adjustments, which need to be done in the energized state, should be carried out with special insulated tools.

In addition, the operating instructions of the manual valve must be observed. They are an integral component of this manual.

4.3 Transport and storage

The actuators must be handled, transported and stored with care. Please note the following points:

- The actuators should be transported and/or stored in their original unopened packaging.
- The actuators must be protected from harmful physical influences such as dust, heat (humidity).
- It is important that the connections are neither damaged by mechanical nor thermal influences.
- Prior to installation, the actuators should be inspected for transport damages. Damaged actuators must not be installed.



Warning

5. Actuator Design

The standard version of the EA 11 electrical actuator consists of the following elements: gear unit, direct current motor, electrical board, and components for end position limiting.

For special applications, the actuator can be equipped additionally with various supplementary kits (see Section 9).

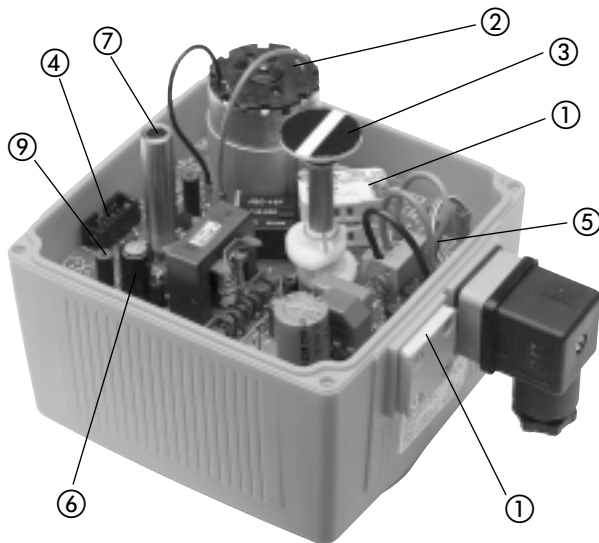

- 1 Limit switches S1 and S2
- 2 Direct current motor
- 3 Optical position indicator
- 4 Plug for accessories
- 5 Terminal strip for external connections
max. 1.5 mm²
- 6 Electrical supply unit, without protection
against accidental contact
- 7 Shaft for emergency manual override
- 8 Connections for DIN plug or
cable gland
- 9 Assembly bolt for accessories

5.1 Wiring Diagram for Standard Version

Position indicator

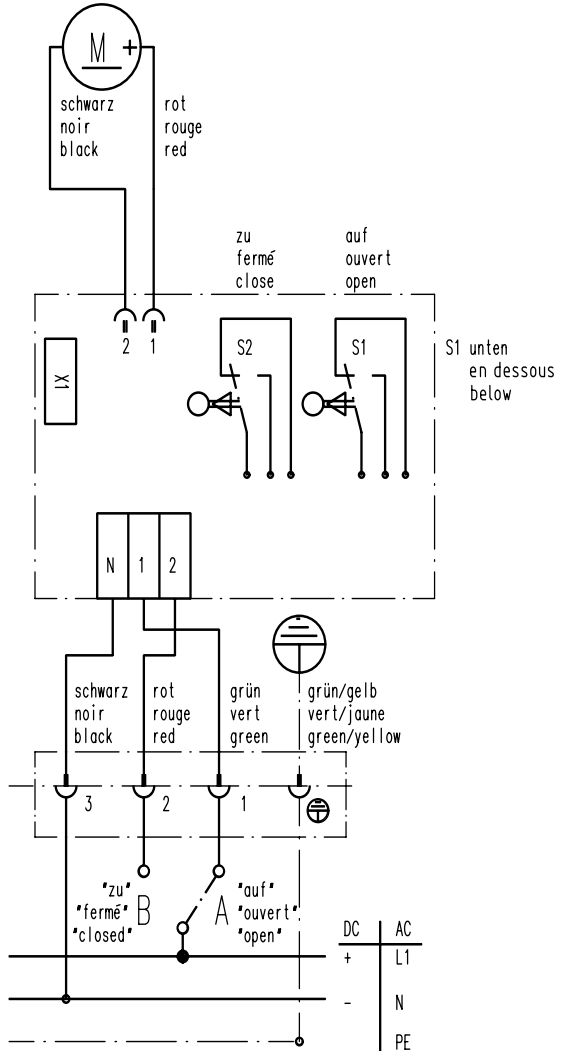
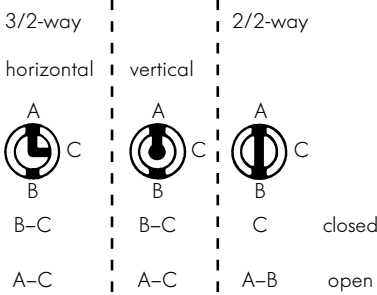

Installationnote

If the actuator is connected direct to the power-supply, it is necessary to install a switch-disconnector between the actuator and the power-supply (do not disconnect the earthcable).

EA11: Basis 700.271.496-02

6. Valve Design

The EA 11 electrical actuator can be mounted on ball valves type 546, DN10–50, by using the correct coupling piece and selecting a suitable adapter plate with clamps.

The actuators are supplied ex works in the «open» position. See Section 6.1 for the individual assembly components required for the ball valve type 107.

Both end positions in the actuator have been preset in the factory. It is necessary to readjust these after installation at the customer (see Section 7).

How to assemble (see Fig. 6.1)

Screw the adapter plate with the fixed clamps tightly onto the actuator (note the cam positions).

Mount the multifunctional module on the ball valve.

- 1 Housing
- 2 Housing cover
- 3 Indexing disk* with switching cams 3a
- 4 Screws
- 5 Connector plug 3P + E per DIN EN 175301-803* (formerly DIN 43650)

* only for MF module version with pre-assembled microswitches

Remove housing cover (2).



The MF module can be mounted on the ball valve type 546 in the opened or closed position.

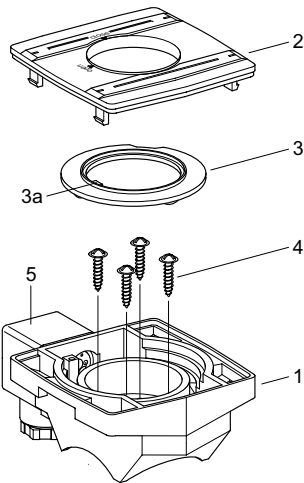

Spigot is asymmetrical.

The spigot position must be identical with one of the two illustrations.

A Spigot position for closed ball valve

B Spigot position for open ball valve

Place the MF module on the ball valve

Make sure the contours match!

Note the square (a) and round (b) contours as well as the position of the asymmetrical recesses (c) of the stem.

Tighten the 4 pre-assembled screws (Torx).
The MF module is now firmly connected with the ball valve.

Insert the coupling and the coupling piece* in the multifunctional module.

Fasten the actuator with the adapter plate to the multifunctional housing using the provided clamps.

*coupling piece only for DN10–25



Actuator and valve must have the same position, «open» or «closed».

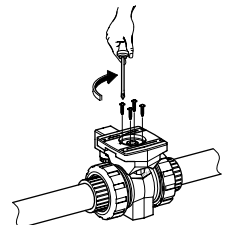
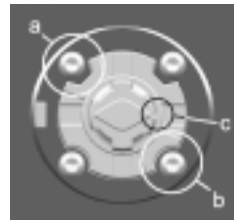
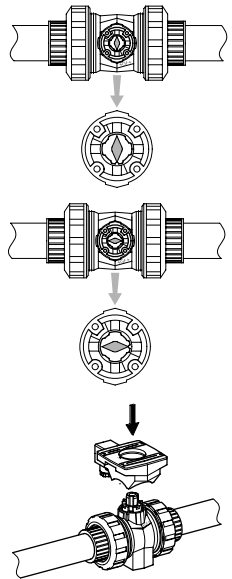

6.1 Ball Valve Type 107

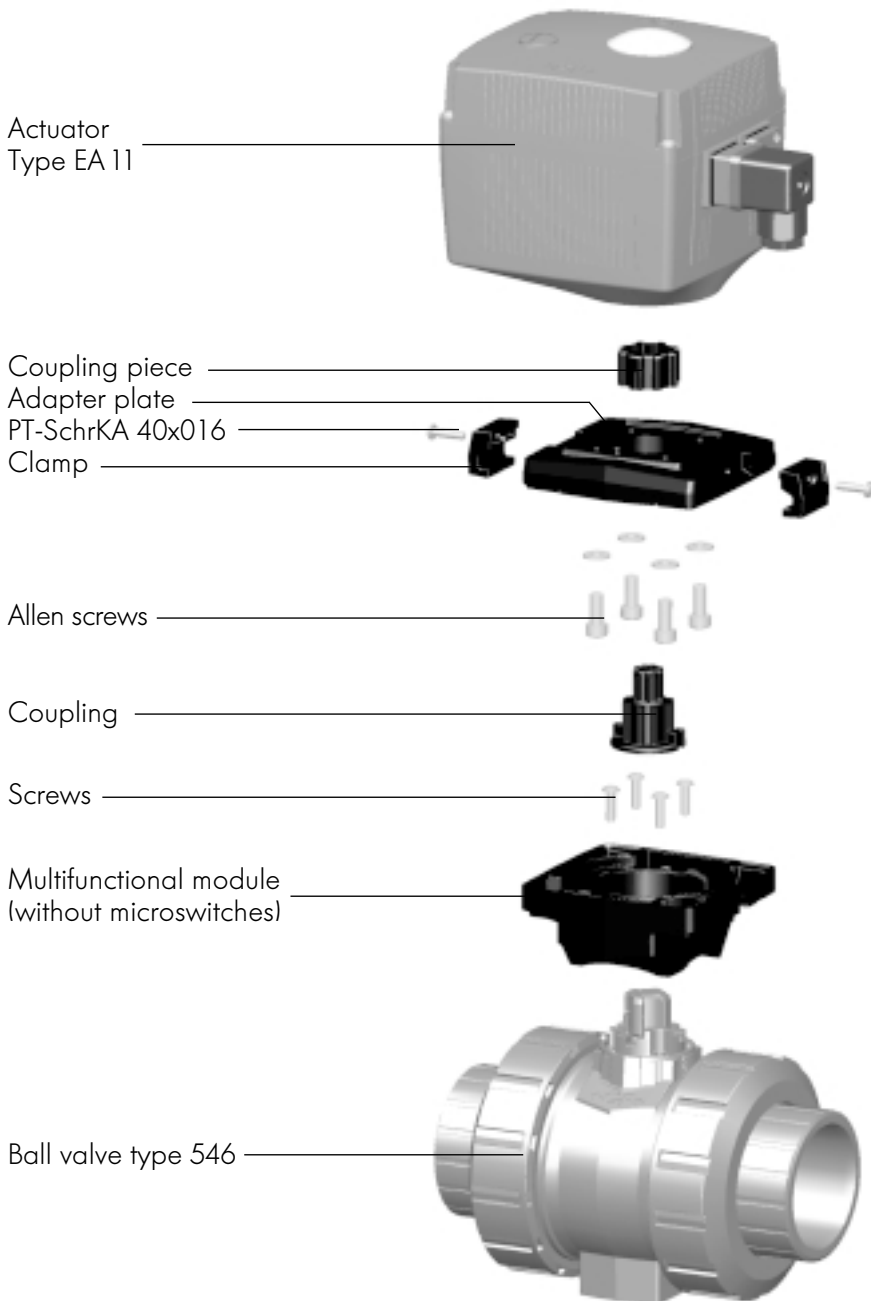

6.2 Overview of Ball Valve System Type 107

- 1 Actuator type EA 11
- 2 Coupling piece DN10–25
- 3 Adapter plate DN10–50
- 4 Multifunctional module DN10–50
- 5 Ball valve type 546 DN10–50

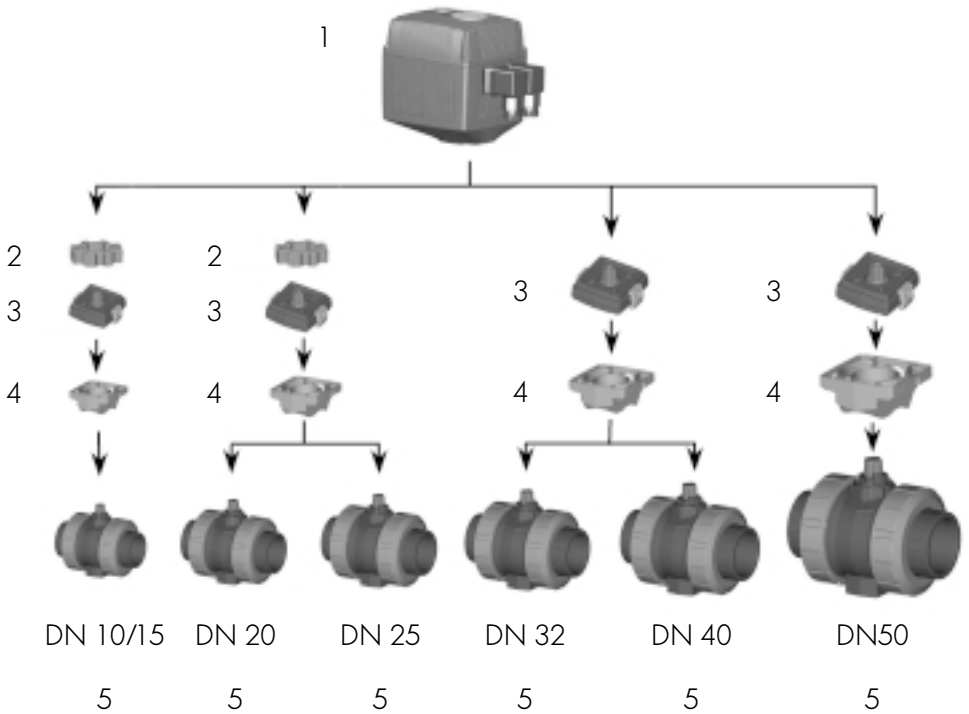

7. Setting Up the Actuator

Attention

Check the following before connecting the actuator to the mains:

- Does the mains voltage correspond to the specifications given on the typeplate
- Has the actuator been connected correctly (see Section 5.1)

Adjustments

If a complete valve is supplied by Georg Fischer, no further adjustments are required.

After installation by the customer or after repair work, the end positions should be checked and if necessary adjusted.

Limit switch allocation

Switch S1 opens at «open» position

Switch S2 opens at «closed» position

Procedure

Set both switching cams (1) to S1* and S2* so that the rotating angle is less than 90°.

Let the actuator turn until a limit switch is activated. By adjusting the respective switching cam, the end position can be set since the actuator follows the cam.

* S1: «open», bottom

S2: «closed», top

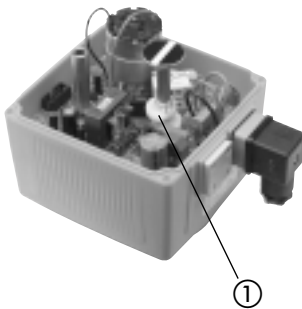

7.1 Emergency Manual Override

Assembly and function

Assembly

Pull the crank (1) out of the retainer

Remove cover screw (2) with the crank (1)

Insert the crank in the hexagon shaft* under the opening

* see illustration, page 60, no. 7



Function

Push the crank down to the stop.

With nine revolutions, the ball is rotated by 90° ↻.

Direction of rotation:

CW = close

CCW = open



Note the «open» and «closed» position on the optical indicator.



8. Technical Specifications

Actuator EA 11

Rated voltage	100–230 V, 50/60 Hz
	24 V =/24 V, 50/60 Hz
Rated output	22 VA at 24 V AC/DC 40 VA at 100–230 V AC
Protection class	IP 65 per EN 60529 ³⁾
Duty cycle	35% at 25 °C
Overload protection	current/time dependent (resetting) ¹⁾
Electrical connections	Connector plug 3 P+E per DIN EN 175301-803 (formerly DIN 43650) additional cable entry point for PG 11
Control time	5 s / 90° at Mdn
Actuating angle	max. 270°, set to 90°
Nominal torque	10 Nm
Peak torque	20 Nm
Ambient temperature	–10° to +45 °C ²⁾
Allowable humidity	max. 80% up to 31 °C ⁴⁾
Pollutiongrade ⁵⁾	2
Overvoltage-category ⁵⁾	II
Housing materials	PP fiberglass reinforced, flame retardant, external stainless steel screws
Position indicator	optical, integrated
Emergency manual override	integrated

¹⁾ Overload protection of the motor is dimensioned so that the motor and the power supply board are protected. As soon as the load is in the torque range, the actuator runs again.

²⁾ For temperatures below –10 °C as well as condensation, the heating element no. 198 190 086 should be built in (see Section 9.1).

³⁾ Protection rating IP67 for use of cable glands and vertical installation.

⁴⁾ Linear decreasing to 50% relative humidity with 40°C

⁵⁾ Per EN 61010-1

9. Mounting and Connecting Supplementary Kits

9.1 Heating element

Description	Technical data	Code
Heating element	24 V=	199 190 086

Wiring diagram

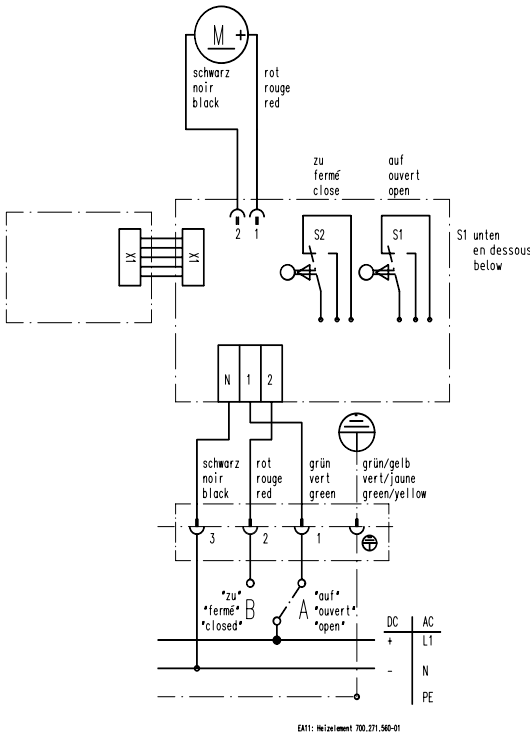

The heating element is mounted on the base board and is connected electrically via a flat cable (X1). The temperature is measured with a temperature sensor, which is mounted on this element, and between approx. 0–5 °C the heating element is switched on or off, respectively.

Mounting the heating element (board)

 Disconnect the actuator from the supply voltage.

Take the board out of its packaging and check for damages.

Attention:

 Do not touch the board itself. Electrostatic discharge can damage the components.

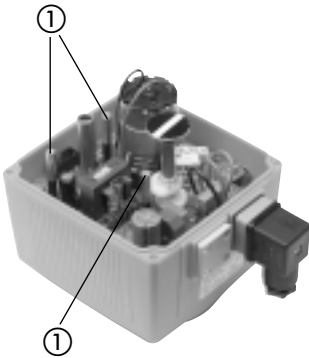

Screw the three distance bolts (1) into the assembly bolts.

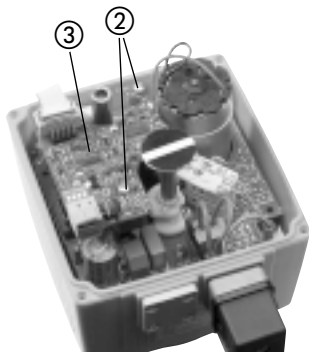

Fasten the board (3) to the distance bolts with the screws (2).

Plug the flat cable into the X1 connector.

Reconnect to supply voltage.

The heating element may not heat at temperatures over +5 °C.

9.2 Fail-safe Return

Description	Technical data	Code
Fail-safe return	24 V=	199 190 085

Wiring diagram

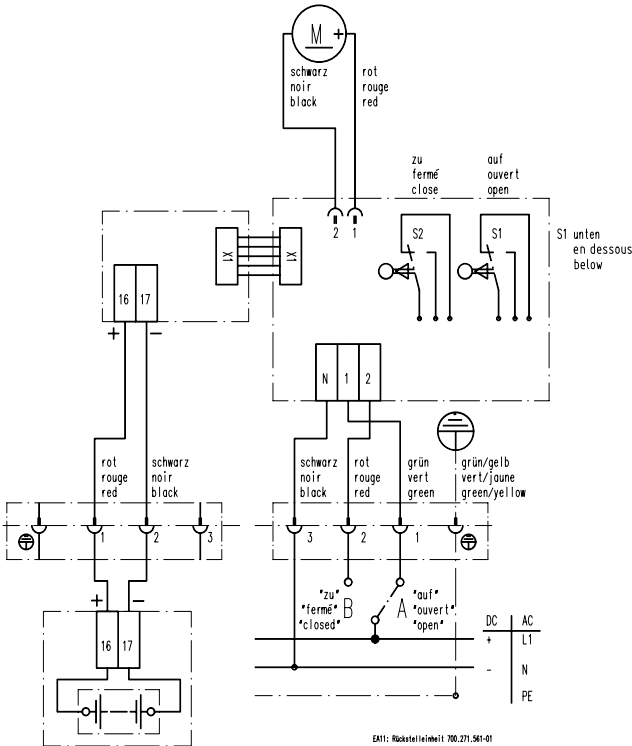

The fail-safe return unit is mounted on the base board and is connected electrically via a flat cable. If the supply voltage is interrupted, the electronics will switch to the storage battery automatically after 5 sec. With a touch control, the function «Go to the CLOSED or OPEN position» can be selected. Position 1/2: CLOSED, position ON: OPEN (always both). The storage battery is charged continuously. Full recharging takes approximately 15 hours.

Mounting the fail-safe return (board)

 Disconnect the actuator from the supply voltage.

Take the board out of its packaging and check for damages.

Attention:

 Do not touch the board itself. Electrostatic discharge can damage the components.

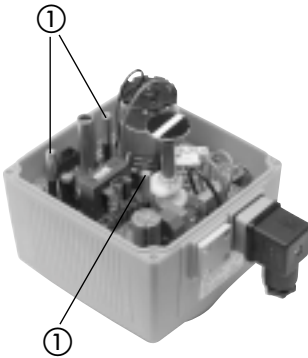

Screw the three distance bolts (1) into the assembly bolts.

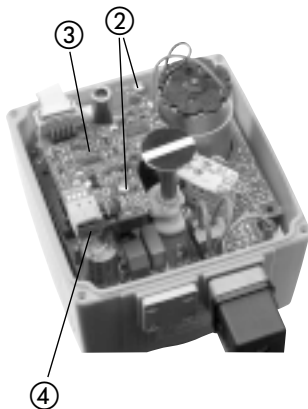

Fasten the board (3) to the distance bolts with the screws (2).

Plug the flat cable into the X1 connector.

Reconnect to supply voltage.

Connect the battery via the second plug or cable gland to the terminals 16 and 17 (4).

**Attention must be given to the polarity.
Charge the battery for at least 12 hours.**

9.3 Additional 2 Limit Switches

Description	Technical data	Code
Kit with 2 additional limit switches Ag, Ni	250 V ~, 6 A	199 190 092

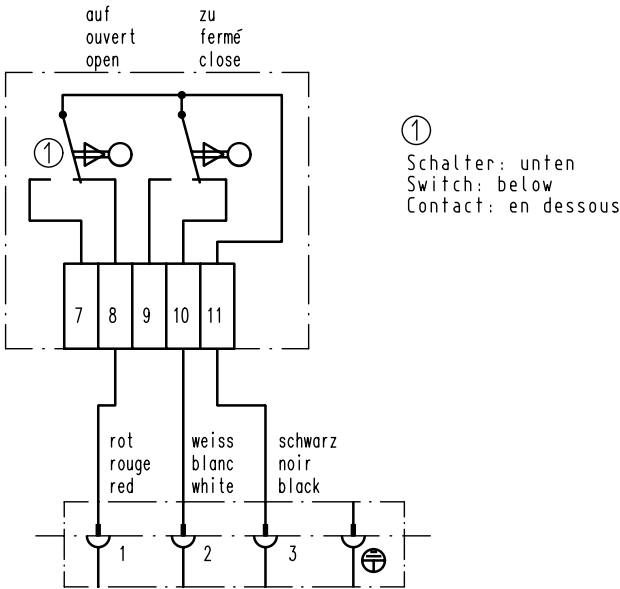

EA11-42: Schalterset 700.271.562-01

If the limit switch kit is mounted in the factory, the switches are wired as opener according to the diagram. It is possible for the customer to convert to closer by rewiring.
 (8 → 7 and 10 → 9).

Mounting the limit switches

 **Disconnect the device from the supply voltage.**

Remove the screws from the limit switch S2 and S1.

Mount the limit switch kit (1) on S1 and S2 as shown.

Tighten with the new, longer screws.

Mount the additional switching cams (2) as well as the spacer rings.

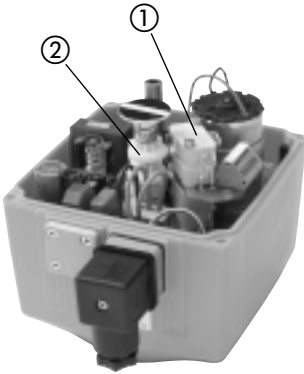

Setting the limit switch position

Reconnect to the supply voltage.

The switching cams can be adjusted with a screwdriver size 2.

Attention:

 An instrument (e.g. ohm meter) must be used for setting the switching position.

Move the actuator to the two end positions and set the respective switching points.

Connect limit switches (disconnect the device from the supply voltage).

Close the actuator with the housing cover and connect to the supply voltage.

10. Fastening Plate

With the fastening plate for the ball valve type 546, forces are absorbed which could occur during valve operation (e.g. initial breakaway torque). In implementing the fastening plate, working forces are not transmitted to the piping system.

In piping systems which are subject to temperature fluctuations, longitudinal or bending forces occur if thermal expansion is hindered. So as not to impair valve functioning, these forces must be absorbed by the appropriate fixed points in front of or behind the valve.



The fastening plate is available in two sizes for the dimension range DN 10 to DN 50. Two screws to fasten on the ball valve are included in the scope of delivery.

Measurement	d 16-32	d 40-63
	DN 15-25	DN 32-50
L	106	149
B	48	54
H	20	20
L1	92	134
L2	62	104
L3	31	52
L4	41	62
L5	25	45
H1	14	14
H2	24	24
D	6.5	8.5
Fastening screws	M6x14	M8x18

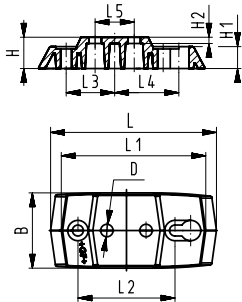

11. Troubleshooting

Problem	Possible causes	Remedy
Motor does not run	No mains voltage (KI 1, 2, 3)	Error at customer side
	Internal wiring error	Check wiring of actuator
	Switching cams S1 and S2 incorrectly set	See Point 4
	Motor blocked	Use emergency manual override, check valve, replace motor
Motor only runs in one direction	Change-over relay does not work	Replace base board
Overload protection reacts (self re-setting)	Friction torque of valve too high	Clean and lubricate valve
	Motor defective	Replace motor
	Duty cycle too high	Increase cycle time
		Reduce ambient temperature
Valve does not close or open correctly	Switching cams S1 and/or S2 not adjusted	See Point 7

For service please contact the specialist at your Georg Fischer sales company.

12. Subassemblies/Spare Parts

Description		Code
Actuator EA11	100–230 V~	198 150 180
Actuator EA11	24 V= / ~	198 150 181
Limit switch kitAg, Ni		199 190 092
Fail-safe return		199 190 085
Heating element		199 190 086
Heating element + fail-safe return		199 190 087
Base board EA11	100–230 V~	198 140 000
Base board EA11	24 V= / ~	198 140 001
Battery kit		198 151 317

Multifunctional module without limit switches (empty)

Dimensions	Code
DN 10/15	167 482 680
DN 20/25	167 482 681
DN 32/40	167 482 682
DN 50	167 482 683

Adapter plate incl. coupling

Dimensions	Code
DN 10/15	198 150 556
DN 20/25	198 150 557
DN 32/40	198 150 558
DN 50	198 150 559

Ball valve type 546 see separate datasheet

GEORG FISCHER +GF+

Piping Systems

- A** Georg Fischer Rohrleitungssysteme GmbH, Sandgasse 16, 3130 Herzogenburg
Tel. +43(0)2782/856 43-0, Fax +43(0)2782/856 64, e-mail: office@georgfischer.at
- AUS** George Fischer Pty Ltd, 186-190 Kingsgrove Road, Kingsgrove NSW 2008, Tel. +61(0)2/95 54 39 77, Fax +61(0)2/95 02 25 61
- B/L** Georg Fischer NV/SA, Digue du Canal 109-111 – Vaardijk 109-111, 1070 Bruxelles/Brüssel
Tél. +32(0)2/556 40 20, Fax +32(0)2/524 34 26, e-mail: info.be@be.piping.georgfischer.com
- BR** George Fischer Ltda, Av. das Nações Unidas 21689, 04795-100 São Paulo, Brasil,
Tel. +55(0)11/5687 1311, Fax +55(0)11/5687 6009
- CH** Georg Fischer Rohrleitungssysteme (Schweiz) AG, Amsler-Laffon-Strasse 1, Postfach, 8201 Schaffhausen
Tel. +41(0)52 631 30 26, Fax +41(0)52 631 28 97, e-mail: info@rohrleitungssysteme.georgfischer.ch
- CHINA** Georg Fischer Piping Systems Ltd Shanghai, No. 218 Kang Qiao Dong Rd., Shanghai 201319
Tel. +86(0)21/58 13 33 33, Fax +86(0)21/58 13 33 66, e-mail: gfsro@public.shanghai.cngb.com
Georg Fischer Piping Systems (Trading) Ltd Shanghai, No 516 Fute Bei Road, Waigaooqiao Free Trade Zone, 200131 Pudong
Shanghai, Tel. +86(0)21/5868 0278, Fax +86(0)21/5868 0264, e-mail: gfrade@sh.cngb.com
- D** Georg Fischer GmbH, Daimlerstraße 6, 73095 Albershausen, Tel. +49(0)7161/302-0, Fax +49(0)7161/302 111
e-mail: info@georgfischer.de, Internet: <http://www.rls.georgfischer.de>
Georg Fischer DEKA GmbH, Kreuzstrasse 22, 35232 Dautphetal-Mornshausen
Tel. +49(0)6468/915-0, Fax +49(0)6468/915 221/222, e-mail: info@dekapipe.de, Internet: <http://www.dekapipe.de>
- DK/IS** Georg Fischer A/S, Rugvænget 30, 2630 Taastrup, Tel. +45 70 22 19 75, Fax +45 70 22 19 76
e-mail: info@dk.piping.georgfischer.com, Internet: <http://www.georgfischer.dk>
- E** Georg Fischer S.A., Alcalá, 85, 2ª, 28009 Madrid, Tel. +34(0)91/781 98 90, Fax +34(0)91/426 08 23,
e-mail: info@georgfischer.es
- F** Georg Fischer S.A., 105-113, rue Charles Michels, 93208 Saint-Denis Cedex 1
Tél. +33(0)1/49 22 13 41, Fax +33(0)1/49 22 13 00, e-mail: info@georgfischer.fr
- GB** George Fischer Sales Limited, Paradise Way, Coventry, CV2 2ST, Tel. +44(0)2476/535 535, Fax +44(0)2476/530 450
e-mail: info@georgfischer.co.uk, Internet: <http://www.georgfischer.co.uk>
- GR** Georg Fischer S.p.A., Athens Branch, 101, 3rd September Str., 10434 Athen
Tel. +30(0)1/882 0491, Fax +30(0)1/881 0291, e-mail: dderiv_piping_gf@oneway.gr
- I** Georg Fischer S.p.A., Via Sondrio 1, 20063 Cernusco S/N (MI), Tel. +39(0)2/921 861, Fax +39(0)2/921 407 85-6
e-mail: office@piping.georgfischer.it
- ID** Georg Fischer Representative Office, c/o Wisma Aria, 3rd Floor, Jl. H.O.S. Kokroaminoto 81, Jakarta 10310, Indonesia
Tel. +62(0)21/391 48 62, Fax +62(0)21/391 48 63
- IND** Georg Fischer Piping Systems Ltd, India Branch Office, Solitaire Corporate Park, 532, Building No. 5, 3rd Floor, Chakala
Ghatkopar Link Road, Andheri (E), 400 093 Mumbai, Tel. +91(0)22/820 2362, Fax +91(0)22/820 2462,
e-mail: branchoffice@georgfischer.net
- J** Georg Fischer Ltd, 13-8, Nanbanaka 1-chome, Naniwa-ku, 556-0011 Osaka
Tel. +81(0)6/6635 2691, Fax +81(0)6/6635 2696, e-mail: info@georgfischer.jp
- N** Georg Fischer AS, Rudsetta 97, 1351 Rud, Tel. +47(0)67 18 29 00, Fax +47(0)67 13 92 92, Internet: <http://www.georgfischer.no>
- NL** Georg Fischer N.V., Postbus 35-8160, 8161 PA Epe, Tel. +31(0)578/678222, Fax +31(0)578/621768
e-mail: info.vgnl@nl.piping.georgfischer.com, Internet: <http://www.georgfischer.nl>
- PL** Georg Fischer Sp. z o.o., ul. Radiowa 1A, 01-485 Warszawa, Tel. +48(0)22/638 91 39, Fax +48(0)22/638 00 94
- RO** Georg Fischer Rohrleitungssysteme AG, Rep. Office Romania, 11 Barbu Delavrancea, 70000 Bucharest - Sector 1
Tel. +40(0)1/222 91 36, Fax +40(0)1/222 91 77, e-mail: office@georgfischer.ro
- RU** Georg Fischer Piping Systems Ltd, Moscow Representative Office, Shremetievskaya ul., 47, 127521 Moscow
Tel. +7 095/219 9604, Fax +7 095/232 3625, e-mail: lazer@orc.ru
- S/FIN** Georg Fischer AB, Box 113, 12523 Älvsjö-Stockholm, Tel. +46(0)8/506 77 500, Fax +46(0)8/749 23 70
e-mail: info@georgfischer.se, Internet: <http://www.georgfischer.se>
- SGP** Georg Fischer Pte Ltd, 15 Kaki Bukit Road 2, KB Warehouse Complex, 417 845 Singapore
Tel. +65(0)67 47 06 11, Fax +65(0)67 47 05 77, e-mail: info@georgfischer.com.sg
- USA** George Fischer Inc., 2882 Dow Avenue, Tustin, CA 92780-7258 Tel. +1(714) 731 88 00, Toll Free 800/854 40 90
Fax +1(714) 731 62 01, e-mail: info@us.piping.georgfischer.com, Internet: <http://www.us.piping.georgfischer.com>
- Export** Georg Fischer Rohrleitungssysteme AG, Ebnatstrasse 111, Postfach, CH-8201 Schaffhausen, Tel. +41(0)52 631 11 11
Fax +41(0)52 631 28 93/631 28 58, e-mail: export@piping.georgfischer.com, Internet: <http://www.piping.georgfischer.com>