



# LEVEL ALERT 2000 Liquid Level Sensor

## Corrosive Liquid Sensor LA2000 Multi-Switch

The PGK LA2000 is an economical, weather resistant liquid level sensor. It is designed to be used with an existing controller, enabling the user to perform various functions or control multiple pumps. This device can stop and start pumps, sound alarms, activate heaters, open and close solenoids, and a variety of other functions.

PGK's LA2000 is available with your choice of 1 to 6 switches, and in 8 inch to 20 foot lengths. The switches are activated by a float rising and lowering with the fluid. Additional floats and stop collars may be added to hold each switch in a latched position. Easy switch to terminal block wiring makes hook-up to your controller simple, and also allows for your choice of 'normally open' or 'normally closed' positions.

**Available** in Polypropylene or KYNAR® (PVDF), maintenance of the LA2000 is extremely simple since it requires only periodic checks of float and column for build-up of foreign matter.

### Optional Features

- ▶ All wetted parts made from Polypropylene or PVDF.
- ▶ Column Lengths from 8 inches to 20 feet.
- ▶ 1 to 6 Switch Positions.
- ▶ Extra Floats and Stop Collars to hold switches in a 'Latched' or 'Unlatched' Position.
- ▶ Full 1.25 inch Inside Float Diameter for liquids prone to build-up of foreign matter.

#### WARRANTY

PGK, Incorporated warrants all instruments manufactured and sold to be free from defects in material or workmanship under normal use and service. The company agrees to repair or replace, at its option, any instrument which its examination reveals to have been defective, due to faulty workmanship or material. Instruments must be returned to PGK, shipping charges prepaid, within ninety (90) days of purchase date. This warranty is expressly in lieu of all other warranties express or implied, and of all obligations or liabilities on its part for damages including but not limited to consequential damages, following the use or misuse of instruments sold by it. No agent or representative is authorized to assume for PGK, Inc. any liability except as set forth above. The company shall not be liable to the customer or others claiming through the customer for special or consequential damages for any reason whatsoever.

Made in the U.S.A. by

## PGK Incorporated

Distributed by:

### KTH Sales, Inc.

Ph: 219-736-0060 • sales@KTHSales.com

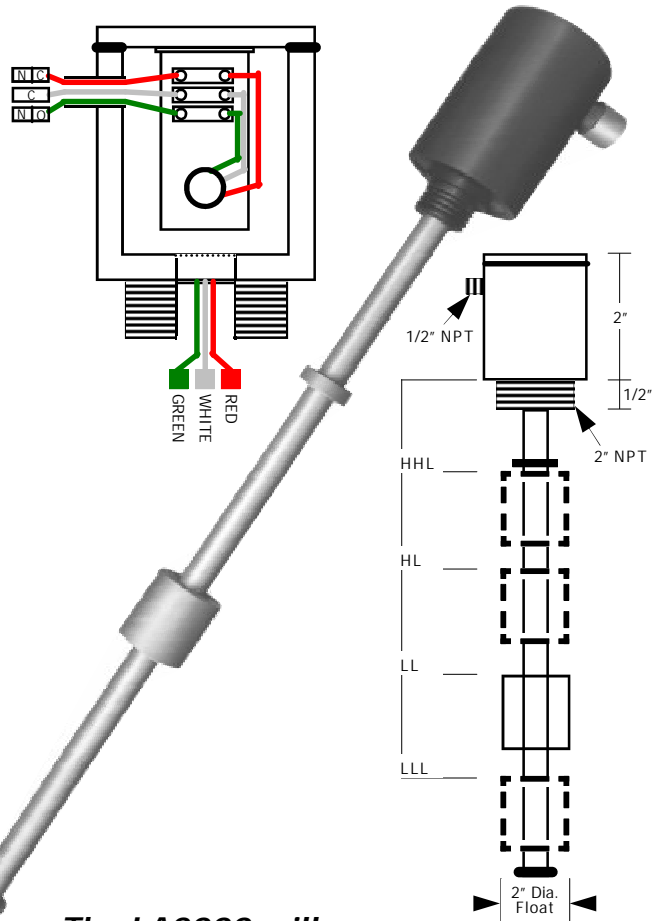

### The LA2000 will...

- ▶ Perform functions such as; Start Pump, Stop Pump, Sound Alarm, Trigger Lights, etc.
- ▶ Operate trouble-free when used with various corrosive and non-corrosive solutions.
- ▶ Alleviate constant physical monitoring of tanks.
- ▶ Prevent overflow from occurring.
- ▶ Stop pump burn-outs due to constant 'on-off' switching.
- ▶ Simultaneously run 2 pumps in separate tanks.

#### Mechanical Specifications

Wetted Parts.....Polypropylene or PVDF  
 Liquid Temperature..... 180 degrees F. Maximum  
 Maximum Pressure..... Atmospheric  
 Minimum Specific Gravity.....0.8  
 Overall Length ..... 8 inches to 20 feet

#### Electrical Specifications

Supply Voltage.....24, 120 or 240 VAC  
 Load Voltage ..... 5.0 amps, 120 VAC  
 Maximum Power Rating..... 10 watts  
 Switch Type..... SPDT