



PVC & CPVC COMPACT BALL VALVES

CB-2-0407

Industrial Grade Sealed Unit



This industrial grade, quarter turn shutoff valve is popular where maintenance-free installations are desired for a variety of chemical processing, industrial and OEM applications. IPS Sizes 1/2" - 4" available with socket, threaded or flanged end connectors, 6" size available with socket or flanged end connectors. 6" valve uses high-efficiency lever style handle for easier operation

Heavy Bodied PVC or CPVC

Construction, Silicone Free Assembly Spears® Compact Ball Valves never rust, scale, or pit, providing exceptional chemical and corrosion resistance. Assembled with water soluble, silicone free lubricant.

PTFE Ball Seats

Spears® PTFE floating seat design reduces seat wear for extended valve life, smooth operation, and bubble-tight shut-off. 100% factory tested.

EPDM or FKM O-ring Options

Choice of high grade, abrasion resistant EPDM or FKM elastomer O-rings allows application specific selection for optimum chemical resistance.

High Impact Polypropylene Handle

Features double-stop engagement and exhibits excellent resistance to most chemical environments.

Full Schedule 80 Bore

In full open position, full bore virtually eliminates pressure drop, providing optimum flow.

Sample Engineering Specifications

All thermoplastic ball valves shall be Compact sealed unit type constructed from PVC Type I, ASTM D 1784 Cell Classification 12454 or CPVC Type IV, Cell Classification 23447. All O-rings shall be EPDM or FKM. All valves shall have Safe-T-Shear® stem and Polypropylene handle. All EPDM valves shall be certified by NSF International for use in potable water service. All 1/2" - 2" valves shall be pressure rated at 235 psi, all 3" - 6" and all flanged valves shall be pressure rated at 150 psi for water at 73° F, as manufactured by Spears® Manufacturing Company.

Safe-T-Shear® Stem

Developed to help prevent line fluids from leaking out in the event of ball valve stem damage. Engineered for high strength, the stem incorporates a special shear point to control accidental breakage. Over-torquing breaks occur above the stem O-ring leaving the seal intact until replacement can be made.

Full Service Pressure Rating for Demanding Applications

1/2" - 2" valves pressure rated to 235 psi at 73° F. 3" - 6" & all flanged valves pressure rated to 150 psi at 73° F.

Suitable For Vacuum Service

Spears® Compact Ball Valves are tested at 26 in. Hg vacuum for one hour with less than 1 in. Hg loss.

NSF Listed for Potable Water

All EPDM Valves are NSF Listed for potable water use.

Optional Accessories

- Round Safety Handle
- Stem Extension Kit
- Mini-Mount Actuation Mounting Kit
- 2" Square/T-Style Operator Nut

For additional information, please refer to Spears® THERMOPLASTIC VALVES & ACCESSORIES PRODUCT GUIDE & ENGINEERING SPECIFICATIONS, V-4 and THERMOPLASTIC VALVES, STRAINERS & ACCESSORIES Price Schedule V-1.



PROGRESSIVE PRODUCTS FROM SPEARS® INNOVATION & TECHNOLOGY

Visit our web site: www.spearsmfg.com

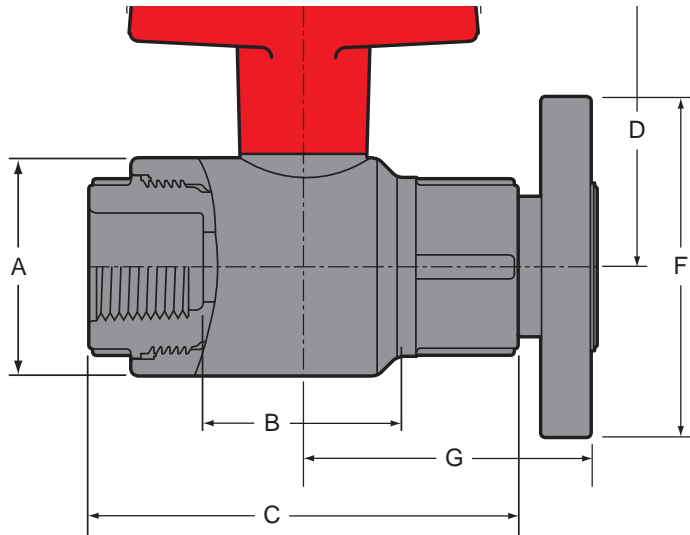

Dimensions, Weight, Operation Torque & Cv Valves

Nominal Size	Dimension Reference (inches, ± 1/16)								Approx. Wt. (Lbs.)		Oper. ² Torque (in.-lb.)	Cv ³ Values	
	A	B ¹		C	D	E ⁴	F	G	PVC	CPVC		Soc/Thd	Flanged
		Socket	Threaded										
1/2	1-11/16	1-5/8	1-7/8	3-3/8	2-5/16	2-3/4	3-1/2	2-17/32	.31	.32	20	36	20
3/4	2-1/8	1-15/16	2-7/16	4-1/16	2-11/16	3-1/4	3-7/8	2-27/32	.49	.52	30	74	42
1	2-7/16	2-1/16	2-3/8	4-7/16	2-7/8	3-3/4	4-1/4	3-1/16	.64	.69	40	141	80
1-1/4	2-13/16	2-3/8	3	4-15/16	3-5/16	4-1/8	4-5/8	3-13/32	.93	.98	60	284	163
1-1/2	3-1/4	2-13/16	3-1/2	5-5/8	3-11/16	4-1/2	5	4	1.39	1.45	80	402	229
2	4-1/16	3-3/8	4-7/16	6-1/2	4-3/8	5-1/4	5-7/8	4-13/32	2.33	2.45	90	706	429
3	5-5/16	4-9/16	5-1/2	8-5/16	5-1/2	7-21/32	7-1/2	5-7/16	4.49	5.02	300	1660	1079
4	7-3/8	6-3/16	7-3/16	10-5/32	6-5/8	10-27/32	9-1/16	6-7/8	9.50	10.24	400	3104	2028
6 ⁴	10-3/16	8	10-3/4	14-1/8	8-1/16	14-5/16	11-1/4	8-21/32	21.48	23.41	900	7942	5268

1: Value Lay Length

2: Torque required at valve maximum internal pressure rating, 5 ft./sec. flow velocity.

3: Gallons per minute at 1 psi pressure loss. Values calculated from valve laying length, based on derivative of Hazen-Williams equation with surface roughness factor of C=150.

4: 6" valve has lever handle, dimension is from valve centerline (not illustrated).

Temperature Pressure Rating

System Operating Temperature ° F (° C)			100 (38)	110 (43)	120 (49)	130 (54)	140 (60)	150 (66)	160 (71)	170 (77)	180 (82)	190 (88)	200 (93)	210 (99)
Valve Pressure Rating psi (MPa)	1/2" - 2"	PVC	235 (1.62)	211 (1.45)	150 (1.03)	75 (.52)	50 (.34)	-0- (-0-)	-0- (-0-)	-0- (-0-)	-0- (-0-)	-0- (-0-)	-0- (-0-)	-0- (-0-)
		CPVC	235 (1.62)	219 (1.51)	170 (1.17)	145 (1.00)	130 (.90)	110 (.76)	90 (.62)	80 (.55)	70 (.48)	60 (.41)	50 (.34)	-0- (-0-)
	3" - 6"	PVC	150 (1.03)	135 (.93)	110 (.76)	75 (.52)	50 (.34)	-0- (-0-)	-0- (-0-)	-0- (-0-)	-0- (-0-)	-0- (-0-)	-0- (-0-)	-0- (-0-)
		CPVC	150 (1.03)	140 (.97)	130 (.90)	120 (.83)	110 (.76)	100 (.70)	90 (.62)	80 (.55)	70 (.48)	60 (.41)	50 (.34)	-0- (-0-)



SPEARS® MANUFACTURING COMPANY CORPORATE OFFICE

15853 Olden St., Sylmar, CA 91342 • PO Box 9203, Sylmar, CA 91392
(818) 364-1611 • www.spearsmfg.com

