



# PVC & CPVC TRUE UNION BALL VALVES (Regular Style)

TU-2-0205

## Multi-Featured Industrial Valve



The unique design features of this quarter-turn shut off valve make it one of the most specified ball valves for industrial and chemical processing applications. Available in IPS sizes 1/2" through 4" with choice of socket, threaded or flanged end connectors, and 6" (venturied 4" valve) with choice of either socket or flanged end connectors. Also available in metric socket sizes 20 mm through 110 mm, and 1/2" through 4" BSP threads.

### Heavy Bodied PVC or CPVC Construction

Spears® True Union Ball Valves never rust, scale, or pit, providing exceptional chemical and corrosion resistance.

### Buttress Threaded Double Union Nuts

Strong Buttress type threads on union nuts and seal carriers allow higher pressure handling capability and quick in-line installation and servicing.

### Safe-T-Blocked® Carrier

Stops flow in either direction, allowing safe removal of the downstream union nut for system service or modification.

### PTFE Ball Seats

Spears® PTFE floating seat design reduces seat wear for extended valve life, smooth operation, and bubble-tight shut-off. 100% factory tested.

### EPDM or FKM O-ring Options

Choice of high grade, abrasion resistant EPDM or FKM elastomer O-rings allows application specific selection for optimum chemical resistance.

### High Impact Polypropylene Handle

Features double stop engagement and exhibits excellent resistance to most chemical environments.

### Safe-T-Shear® Stem

Developed to help prevent line fluids from leaking out in the event of ball valve stem damage. Engineered for high strength, the stem incorporates a special shear point to control accidental breakage. Over torquing breaks occur above the stem O-ring leaving the seal intact until repair or replacement can be made.

For additional information, please refer to Spears® THERMOPLASTIC VALVES & ACCESSORIES PRODUCT GUIDE & ENGINEERING SPECIFICATIONS V-4 and THERMOPLASTIC VALVES & ACCESSORIES Price Schedules V-1.

### Full Schedule 80 Bore

In full open position, full bore virtually eliminates pressure drop, providing optimum flow.

### Full 235 psi Pressure Rating

Maximum Internal Pressure at 73°F for the most demanding applications of 1/2" - 2" valves, 150 psi for 2-1/2" - 6" and all flanged valves.

### Suitable For Vacuum Service

Spears® True Union Ball Valves are tested at 26 in. Hg vacuum for one hour with less than 1 in. Hg loss.

### NSF® Listed for Potable Water

All True Union Ball Valves are NSF® Certified for potable water use.

### Fully Repairable

Convenient Seat & O-ring Replacement Kits, or Full Cartridge Replacement Kits for easy ordering, servicing and extended valve life.

### Easy Field Actuation, or Custom Factory Actuation Available

Easily actuated in the field using optional mounting kits listed below. Spears® in-house actuation program can quickly fit mechanical actuation to specific application needs.

### Optional Accessories

- Round Safety Handle
- Stem Extension Kit
- Multi-Mount Valve Mounting Brackets
- Complete Multi-Mount Actuation Mounting Kit
- Mini-Mount Actuation Mounting Kit
- 2" Square/T-Style Operator Nut

### Sample Engineering Specification

All thermoplastic ball valves shall be True Union type constructed from PVC Type I, ASTM D 1784 Cell Classification 12454 or CPVC Type IV, ASTM D 1784 Cell Classification 23447. All O-rings shall be EPDM or FKM. All valves shall have Safe-T-Shear® stem and double stop Polypropylene handle. All valve union nuts shall have Buttress threads. All seal carriers shall be Safe-T-Blocked®. All valve components shall be replaceable. All 1/2" - 2" valves shall be pressure rated at 235 psi and all 2-1/2" - 6" and all flanged valves shall be pressure rated at 150 psi for water at 73° F, as manufactured by Spears® Manufacturing Company.



**PROGRESSIVE PRODUCTS FROM SPEARS® INNOVATION & TECHNOLOGY**

Visit our web site: [www.spearsmfg.com](http://www.spearsmfg.com)

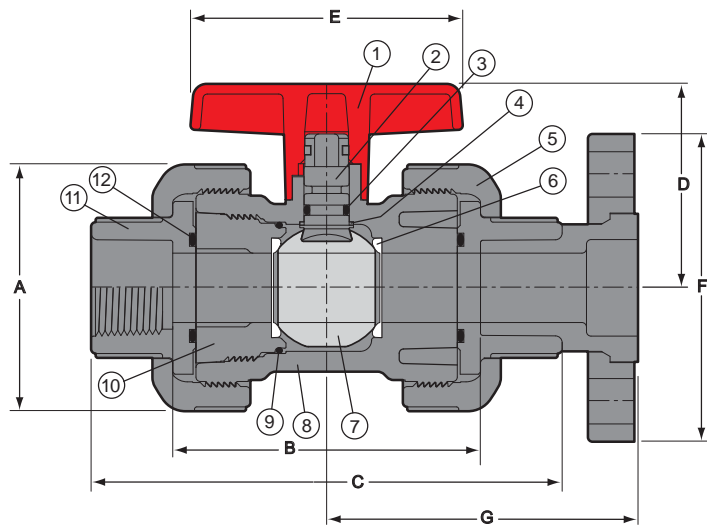

## Replacement Parts

No.	Component	Qty.	Material
1	Handle	1	PP
2	Stem	1	PVC/CPVC
3	Stem O-ring	1	EPDM/FKM
4	Stem Bearing*	1	PP
5	Union Nut	2	PVC/CPVC
6	Seat**	2	PTFE
7	Ball	1	PVC/CPVC
8	Body	1	PVC/CPVC
9	Carrier O-ring	1	EPDM/FKM
10	Seal Carrier	1	PVC/CPVC
11	End Connector	2	PVC/CPVC
12	End Connector O-ring	2	EPDM/FKM

\* sizes 1-1/4" and larger.

\*\*Seat O-ring (not shown) on sizes 2-1/2" and larger.

Nominal Size	Dimension Reference (inches, ± 1/16)							Approx. Wt. (Lbs.)				Oper. <sup>2</sup> Torque (in.-lb.)	C <sub>v</sub> <sup>4</sup> Values	
	A	B <sup>1</sup>	C	D	E	F	G	PVC		CPVC			Soc/Thd	Flanged
								Soc/Thd	Flanged	Soc/Thd	Flanged			
1/2	2-9/16	3-7/16	5-3/16	2-13/32	2-23/32	3-1/2	3-15/32	1.05	1.23	.95	1.14	20	25	18
3/4	3-1/32	4-1/16	6-3/16	2-5/8	3-3/16	3-7/8	4	1.44	1.64	1.50	1.73	30	51	36
1	3-13/32	4-5/16	6-9/16	2-13/16	3-23/32	4-1/4	4-5/16	1.91	2.22	2.08	2.43	40	97	67
1-1/4	3-11/16	4-1/2	7-1/16	2-31/32	4-1/8	4-5/8	4-19/32	2.38	2.78	2.52	2.91	60	204	142
1-1/2	4-3/8	5-5/16	8-1/32	3-9/32	4-15/32	5	5-9/32	3.63	4.00	3.82	4.26	80	285	201
2	5-3/16	5-13/16	8-13/16	4-13/32	5-1/4	6	5-23/32	5.40	6.14	5.70	6.54	90	540	381
2-1/2	7-7/16	8-3/8	11-7/8	4-29/32	9-7/8	7	7-3/16	12.87	14.26	13.44	15.85	300	712	512
3	7-7/16	8-3/16	11-15/16	4-29/32	9-7/8	7-1/2	7-11/32	13.24	15.67	13.85	16.96	300	1294	925
4	8-15/16	8-11/16	13-3/16	5-19/32	10-13/16	9-1/16	8-5/32	19.58	24.32	20.49	25.83	400	2629	1868
6 Socket <sup>3</sup>	8-15/16	19-5/8	26-1/16	6-3/4	10-13/16	11-1/4	14-11/16	22.66	30.98	26.11	34.78	400	N/A	N/A
6 Flanged <sup>3</sup>	11-3/16	29-3/8	N/A	6-3/4	10-13/16	11-1/4	14-11/16	N/A	N/A	N/A	N/A	400	N/A	N/A

1: Valve Lay Lengths.

2: Torque required at valve maximum internal pressure rating, 5 ft./sec. flow velocity.

3: Consists of 4" True Union Ball Valve with two 4" x 6" Adapters.

4: Gallons per minute at 1 psi pressure drop. Values calculated from valve laying length, based on derivative of Hazen-Williams equation with surface roughness factor of C=150.

C<sub>v</sub>: Values for 6" venturied flange and socket valves are not available.

## Temperature Pressure Rating

System Operating Temperature ° F (° C)			100 (38)	110 (43)	120 (49)	130 (54)	140 (60)	150 (66)	160 (71)	170 (77)	180 (82)	190 (88)	200 (93)	210 (99)
Valve Pressure Rating psi (Mpa)	1/2" - 2"	PVC	235 (1.62)	211 (1.45)	150 (1.03)	75 (.52)	50 (.34)	-0- (-0-)	-0- (-0-)	-0- (-0-)	-0- (-0-)	-0- (-0-)	-0- (-0-)	-0- (-0-)
		CPVC	235 (1.62)	219 (1.51)	170 (1.17)	145 (1.00)	130 (.90)	110 (.76)	90 (.62)	80 (.55)	70 (.48)	60 (.41)	50 (.34)	-0- (-0-)
	2-1/2" - 6"	PVC	150 (1.03)	135 (.93)	110 (.76)	75 (.52)	50 (.34)	-0- (-0-)	-0- (-0-)	-0- (-0-)	-0- (-0-)	-0- (-0-)	-0- (-0-)	-0- (-0-)
		CPVC	150 (1.03)	140 (.97)	130 (.90)	120 (.83)	110 (.76)	100 (.70)	90 (.62)	80 (.55)	70 (.48)	60 (.41)	50 (.34)	-0- (-0-)

Note: All flanged valves are rated at 150 psi @73° F



## SPEARS® MANUFACTURING COMPANY CORPORATE OFFICE

15853 Olden St., Sylmar, CA 91342 • PO Box 9203, Sylmar, CA 91392  
(818) 364-1611 • www.spearsmfg.com

